

The Cell Cycle and Mitosis

Textbook pages 150–165

Before You Read

How do cells replace themselves? Record your ideas on the lines below.



Mark the Text

Create a Chart

Highlight the text that describes the three stages of the cell cycle. In a different colour, highlight text that describes how cells divide. Use the highlighted text to create a chart about the life of a cell.

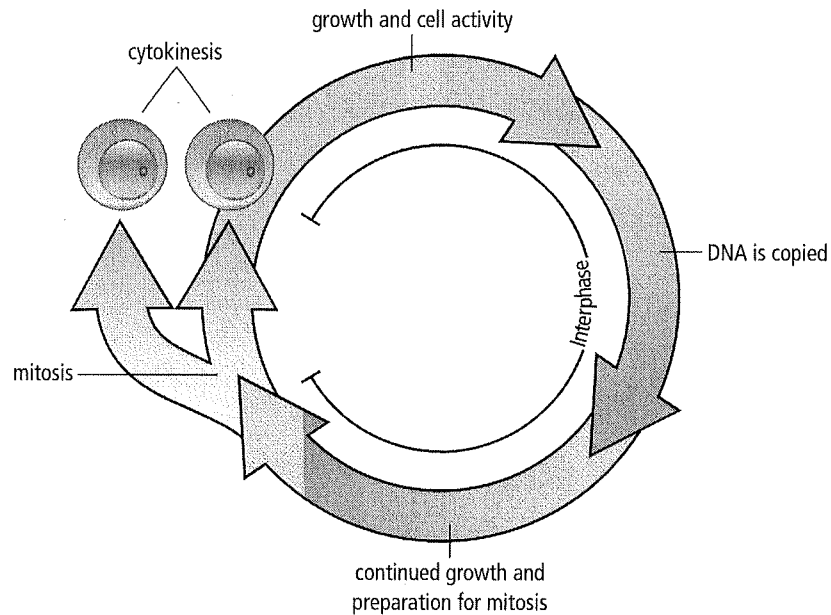

What is the cell cycle?

The three stages of the life of a cell together are called the **cell cycle**. These three stages are:

- ◆ **interphase:** This stage makes up most of the life of the cell. During interphase, cells grow and carry out their life functions. In cells that will divide, the nucleus makes a copy of its DNA in a process called **replication**.
- ◆ **mitosis:** During this stage, the nucleus of the cell divides into two equal and identical parts. Each part has a copy of the DNA.
- ◆ **cytokinesis:** During this stage, the two equal, identical parts of the cell separate. The result of this stage is two identical cells, each with a nucleus and DNA. ✓



Reading Check

1. What are the three stages in the life of a cell?

What are the phases of mitosis?

There are four phases of mitosis. These phases are prophase, metaphase, anaphase, and telophase.

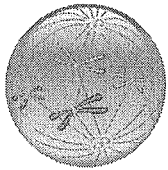
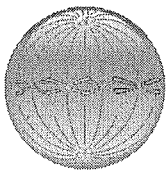
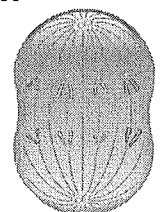
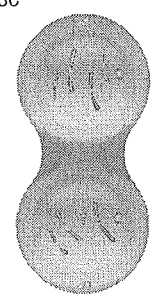
Phases of mitosis	What happens
prophase 	<ul style="list-style-type: none"> the duplicated chromosomes form into an X shape and the nucleolus disappears. spindle fibres, which are tiny tube-like structures made of protein, begin to form in plant and animal cells
metaphase 	<ul style="list-style-type: none"> the duplicated chromosomes line up across the middle of the cell
anaphase 	<ul style="list-style-type: none"> the duplicated chromosomes move apart to opposite ends of the cell
telophase 	<ul style="list-style-type: none"> a nucleolus forms around the chromosomes at the opposite ends of the dividing cell

How can mutagens affect the cell cycle?

Mutagens can cause changes in the cell cycle so that cells keep dividing continuously. The cells pile up on top of one another, forming a lump called a tumour. The uncontrolled cell division sometimes results in diseases called **cancers**. Cancerous cells may grow in one place in the body, or they may spread to other parts of the body where they will continue to divide. ✓

 **Reading Check**

2. What is cancer the result of?

Use with textbook pages 153–158.

Getting to know the cell cycle

Vocabulary	
anaphase	mitosis
cell cycle	nucleolus
cytokinesis	nucleus
DNA	prophase
duplicated chromosomes	telophase
four	three
interphase	two
metaphase	

Use the terms in the vocabulary box to fill in the blanks. You can use each term more than once. You will not need to use every term.

- There are _____ stages in the life of a cell.
- The stage that makes up most of the cell's life is _____.
During this stage, cells grow and carry out their life functions. In cells that will divide, the nucleus makes a copy of its _____.
- During _____, the nucleus of the cell divides into two equal and identical parts. Each part has a copy of the DNA.
- During _____, the two equal, identical parts of the cell separate. This stage forms _____ identical cells with a nucleus and DNA.
- There are _____ phases of mitosis.
- In _____, the duplicated chromosomes contract into an X shape and the _____ disappears.
- In _____, the _____ line up across the middle of the cell.
- In _____, the _____ move apart to opposite ends of the cell.
- In _____, a _____ forms around the chromosomes at the opposite ends of the dividing cell.

Name _____

Date _____

Use with textbook pages 150–165.

Identifying stages of the cell cycle

Vocabulary	
continued growth and preparation	growth and preparation
cytokinesis	interphase
replication	mitosis

Use the vocabulary words in the box above to label the stages of the cell cycle in the following diagram.

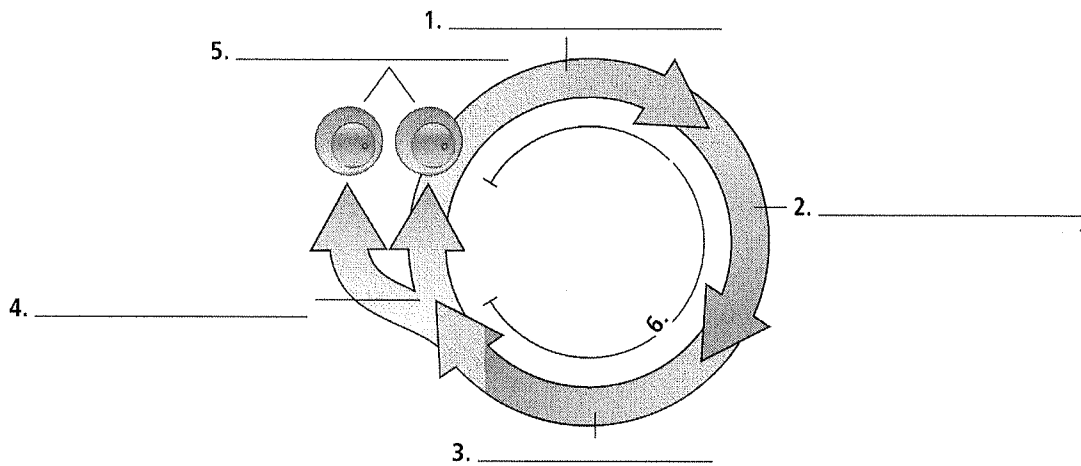

Briefly describe what is occurring in each stage of the cell cycle.

1. _____

2. _____

3. _____

4. _____

5. _____

6. _____

Name _____

Date _____

Use with textbook pages 156-157.

Mitosis

Summarize what is happening in the cell for each phase of mitosis. Then draw a labelled diagram of each phase.

Phase	What is happening in the cell?	Labelled diagram
prophase		
metaphase		
anaphase		
telophase		